

Bin Activators

Solids Discharging Devices



The three main types of flow problems when discharging from silos are: bridging, rat holing and segregation.

Shaking the container generally discharges the product, which may be difficult and dangerous when the container is a 200 ton silo. The solution to this problem is to shake the contents not the container.

Utilizing a flexible sleeve between the container, and placing a cone under the material, it is possible to shake the contents without shaking the container.

Bin Activators work by the application of vibrations to the cone which de-aerates the product. The product will bridge, and the bridge will be broken by the vibration.

Flow is ensured but not regulated.

Bin Activators are required anywhere that it is essential to be sure the material is discharging from the silo.



Bin Activators

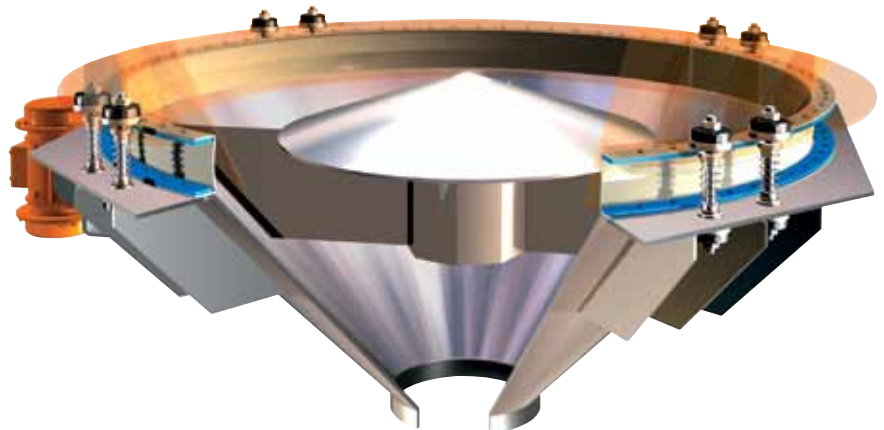

WAM® has been manufacturing bin activators since the early 1980s. Since then the equipment has exhibited excellent quality and performance features in thousands of applications all over the world. As a result, the current WAM® Bin Activator models are the most technically advanced discharging devices for powders or granules from bins, silos or hoppers available on the market today. They offer some unique benefits to users in virtually all industries for a wide variety of installations. WAM® has introduced into an apparently simple piece of equipment some significantly innovative design features in order to even further increase performance and reliability in operation. WAM®'s great experience in designing and manufacturing Bin Activators has resulted in a comprehensive product range completed by a vast selection of matching accessories and ancillary equipment.

CONE

WAM® takes pride in offering seamless cones industrially manufactured in-house on automatically operating metal spinning lathes. The contact surfaces of the particularly robust cones, which are available in carbon steel or 304L/316L stainless steel, are perfectly smooth.

SLEEVE SEAL

WAM®'s Bin Activators are all equipped with an easy-to-fit flanged seamless sleeve seal manufactured from in-house polymer cast SINT™ER. Thanks to its particular geometry and a special industrial manufacturing process, any welding, glueing or sewing process is avoided. The special design prevents slipping of the seal, material leakage and ensures high durability over time. The excellent mechanical characteristics of SINT™ER guarantee high resistance to stress inflicted by vibration, or by excessive or suction pressure conditions inside the silo. The absence of clamp retainers eliminates the risk of cutting or puncturing of the sleeve. Durability is further increased by the mounting position outside the material flow. For food-grade applications the same seals are available in FDA-approved SINT™AL engineering polymer.

SUSPENSIONS

WAM® suspensions ensure that vibrations generated agitate the cone rather than the bin, hopper or silo structure. Unlike the unidirectionally operating conventional hanger shape suspensions, WAM®'s tubular shape suspensions enable a 360-degree movement which provides complete absorption of vibrations. Furthermore, oscillation required is considerably less with the WAM® type which results in smaller size vibrators.

VIBRATION

Thanks to the innovative configuration of WAM® Bin Activators, the installed drive power of the vibrators is relatively low, with the eccentric weights adjusted at 20% leaving a sufficient margin of increase. If required, retro-adjustment is easily done. WAM® favors the assembly of high performance vibrators warehoused in the U.S. in large numbers by WAMGROUP™ associates OLI.

BAFFLE PLATES

Depending on the application, baffle plates come in different configurations and angles (optionally 15, 30, 45 or 60 degrees). For large diameters special stepped angle deflector baffle plates are available.



SUSPENSIONS

- Heavy-duty
- 360-degrees movement
- No large size vibrators required

ELECTRIC MOTOR-VIBRATORS

- Asynchronous three-phase motor
- Vibrator with adjustable eccentric weights
- OLI vibrator motors are easy to install and to retro-fit



SLEEVE SEAL

- Manufactured from highly resistant engineering polymer SINT™ER: suitable for all applications
- FDA-approved engineering polymer SINT™AL available

BAFFLE PLATES

- Convex deflector baffle plate
- Conical deflector baffle plate with 15° - 30° - 45° - 60° angle
- Compound deflector baffle plate and to retro-fit

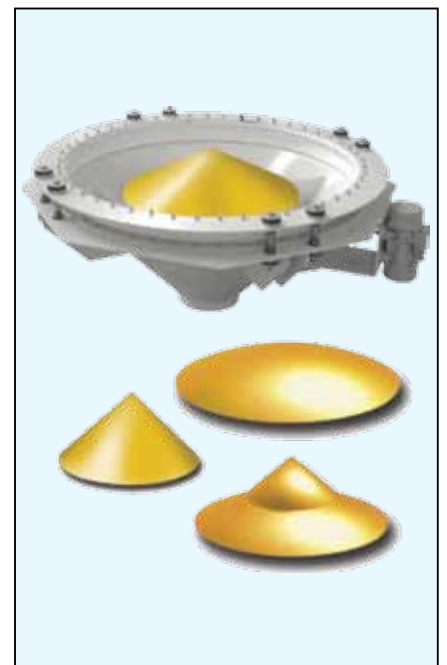

EASY ASSEMBLY

To ease installation and commissioning, WAM® supplies their BA Bin Activators as a kit complete with simple and clear assembly instructions (only positioning and nuts-and-bolts fitting operations are required). To retrofit existing bins, silos or hoppers with a BA-type Bin Activator, in advance WAM® optionally supplies a matching high definition plasma cut flange for on-site welding to the structure.

OPTIONS & ACCESSORIES

- Additional material aeration device
- Outlet spout complete with emergency slide gate

APPLICATIONS

- Flour Milling
- Feed Milling
- Fertilizers
- Chemicals
- Plastics
- Ceramics
- Glass
- Products

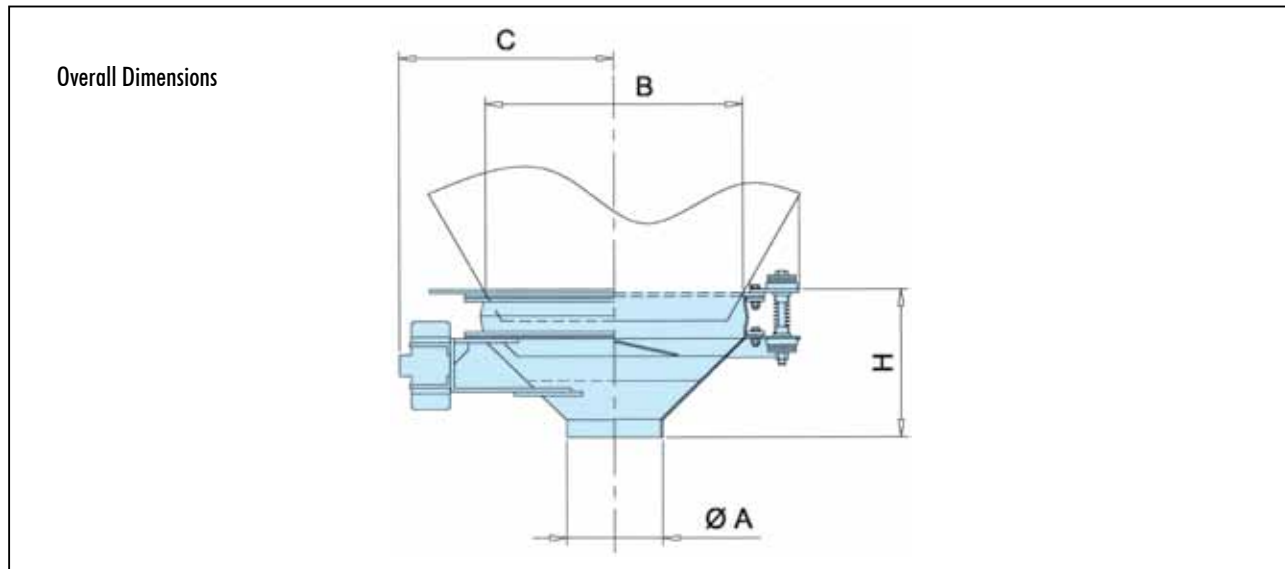

TYPE	Size ft (mm)	Standard Outlet		C in (mm)	H in (mm)	Vibrator Motors		Weight lb (kg)
		A in (mm)	B in (mm)			Qty.	HP 60 Hz	
BA.x.040.	1.3 (400)	4 (102)	15 (380)	16.8 (427)	13 (330)	1	0.13	130 (59)
BA.x.060.	2 (600)	6 (168)	22.8 (580)	20.4 (519)	16.1 (408)	1	0.13	176 (80)
BA.x.090.	3 (900)	8.6 (219)	34.6 (880)	26.9 (684)	20.9 (531)	1	0.25	300 (134)
BA.x.125.	4 (1,250)	10.7 (273)	48.4 (1,230)	36.9 (937)	28.7 (730)	1	0.5	630 (285)
BA.x.150.	5 (1,500)	12.7 (323)	59.1 (1,500)	44.1 (1,120)	30.5 (774)	1	1.0	1,160 (526)
BA.x.180.	6 (1,800)	12.7 (323)	70.9 (1,800)	47.0 (1,194)	36.4 (924)	2	1.0	1,380 (628)
BA.x.210.	7 (2,100)	16.0 (406)	82.7 (2,100)	55.9 (1,420)	40.7 (1,033)	2	1.0	1,940 (880)
BA.x.250.	8 (2,500)	16.0 (406)	97.6 (2,480)	67.1 (1,705)	51.4 (1,307)	2	1.5	3,130 (1,420)
BA.x.300.	10 (3,000)	16.0 (406)	117.3 (2,980)	77.0 (1,955)	61.5 (1,563)	2	1.5	5,120 (2,320)





WAM Inc.
Georgia Division
75 Boulderbrook Circle
Lawrenceville, GA 30045
Tel.: (770) 339 - 6767
Fax: (770) 339 - 4727
wamgeorgia@waminc.com
www.extrac-usa.com
www.waminc.com

WAM Inc.
Texas Division
1300 Triad Blvd.
Fort Worth, TX 76131
Tel.: (817) 232 - 2678
Fax: (817) 232 - 2676
wamtexas@waminc.com
www.extrac-usa.com
www.waminc.com

Further Products

